

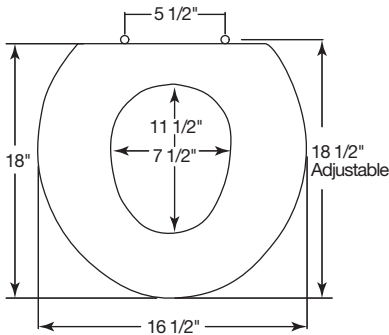

RESIDENTIAL PLASTIC SEATS

SOLACE 480CP

- ROUND OR ELONGATED SEAT, CLOSED FRONT WITH COVER
- SOLID PLASTIC
- POSTUREMOLD® DESIGN
- OVERSIZED FOR EXTRA COMFORT



Ring thickness is 7/8"
Ring thickness including the bumper is 23/32"
Height of the seat with cover is 2"

Seats shall be No. 480CP as manufactured by Church Seats. Seats shall be heavy weight and injection molded of solid plastic. Seats shall be closed front with cover to fit round and elongated bowls. Seats are 3/4" wider on each side to provide extra comfort and feature exclusive Posturemold® design. Large molded-in bumpers for easy cleaning. Seats shall contain our CP hinge, our strongest hinge on a covered seat, made of chrome-plated brass. Pintles will be stainless steel. This sturdy hinge design will prevent wobbling. Color to be white.

**** ANSI Z124.5 section 5.1.2 Tests have shown that this product will support weights up to 500 pounds.****
(Contact Church Seats Co., for test data)

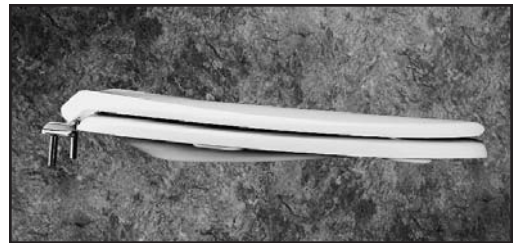

TWO-POSITION HINGE FITS ROUND AND ELONGATED BOWLS